

NOTE:

1. DO NOT SCALE DRAWING.
2. DIMENSIONS ARE IN INCHES/(MM).
3. MINIMUM HEADER SIZE 1-3/4" X 4"
4. CUT OUT FOR COVER PLATE
3-3/4" X 15-3/4".
5. CLEARANCE BETWEEN HEADER AND DOOR 1/8".
6. 90° HO MODELS NOMINAL HOLD OPEN AT 88°
105° HO MODELS NOMINAL HOLD OPEN AT 103°.
7. AUXILIARY STOP REQUIRED COINCIDING WITH DEADSTOP ON RTS CLOSER.

FOR 8-32 MACHINE SCREWS USE No.29 (0.136")
DRILL AND TAP THREE (3) HOLES

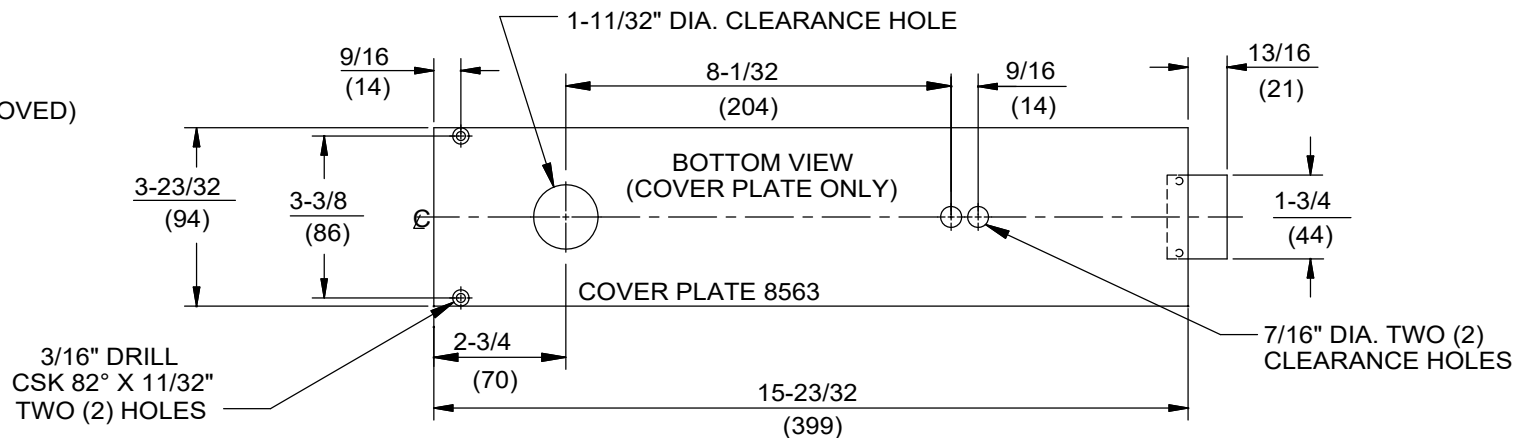
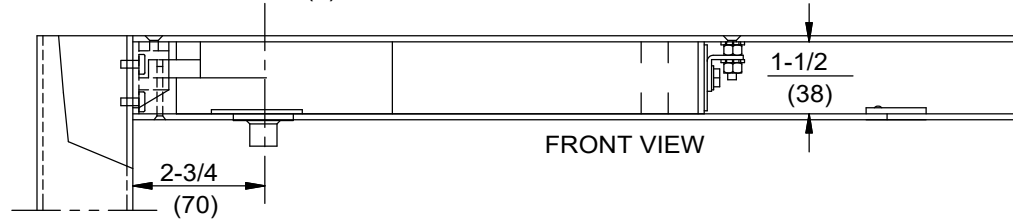
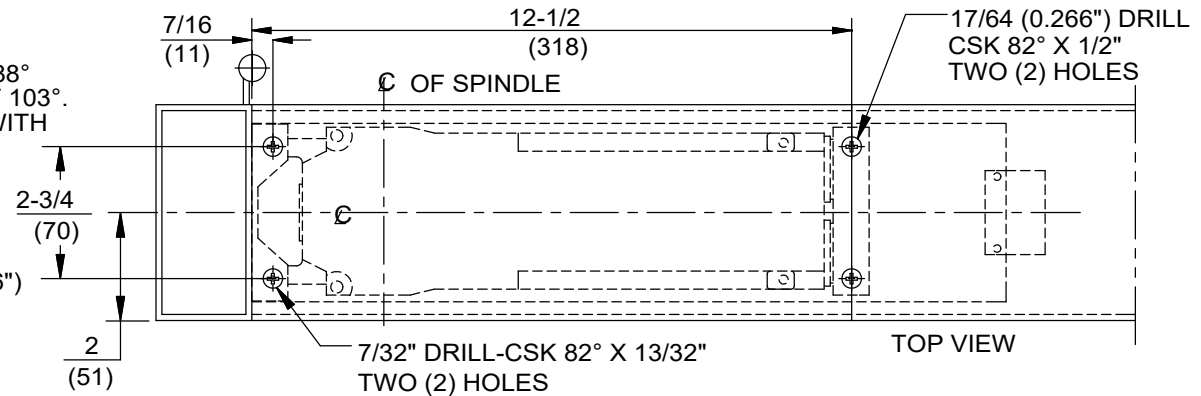
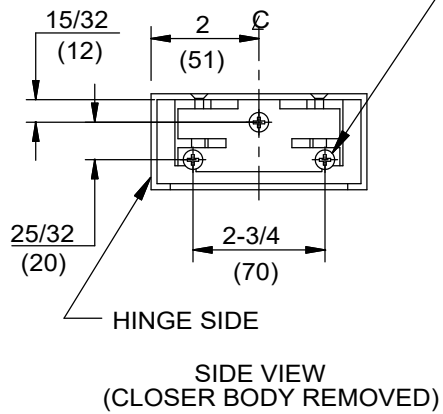

DOOR CLOSER MODEL: RTS SERIES PACKAGE 25, ALUMINUM DOOR AND FRAME PREPARATION, DOOR HUNG ON 4-1/2" WIDE BUTT HINGES, No. 8812 TRACK ARM, No. 8563 COVER PLATE

